

客户名称:

输出端

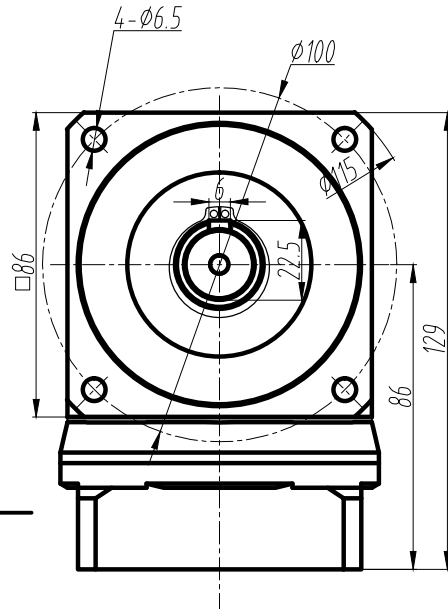

输入端

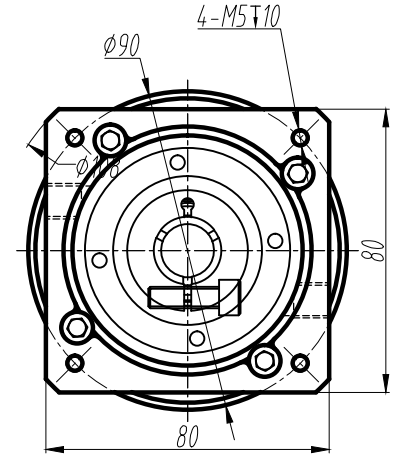
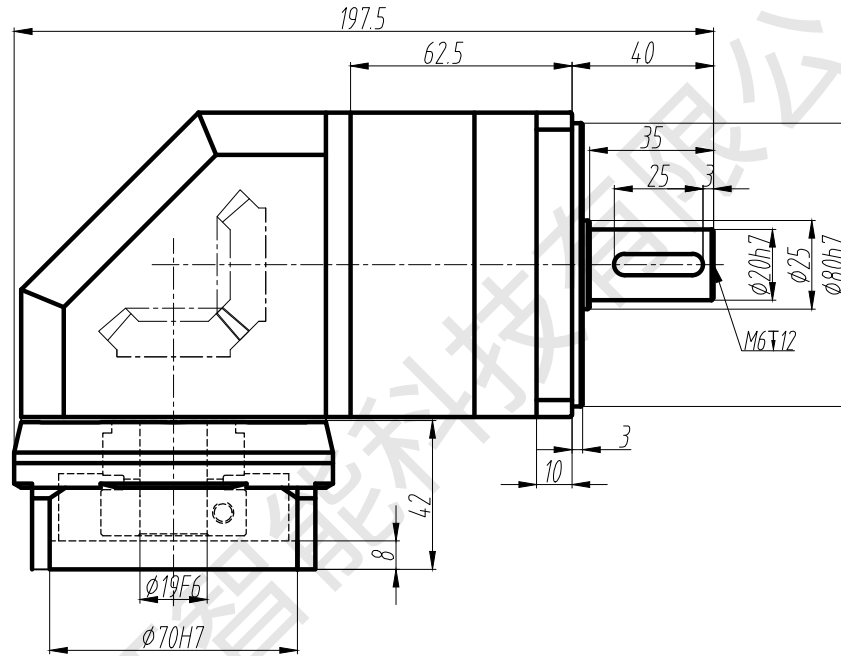

技术参数 technical parameter			
额定输出转矩 Nominal torque	Nm	最大输出转矩 Max.output torque	Nm
额定输入转速 Rated input speed	3000rpm	最大输入转速 Max.input speed	6000rpm
最大径向力 Max.radial force	1050N	输出转速100rpm, 输出轴长1/2处为受力 Speed 100rpm,Axial length 1/2 stress	
最大轴向力 Max.axial force	850N	输出转速100rpm, 输出轴长1/2处为受力 Speed 100rpm,Axial length 1/2 stress	
满载效率 Maximum efficiency	94%	使用温度 Operating temp	-25~ +90°
安装方式 Installation method	任意 arbitrarily	润滑方式 Lubrication mode	长效润滑 Permanent
重量 Weight	4.5kg	寿命 Average life span	20000h
防护等级 Protection level	IP65	法兰精度 Flange accuracy	DIN 42955-R
标准侧隙 Standard backlash	≤10arcmin	精密侧隙 Precise backlash	
输出键标准 Key standard	圆头普通平键 Round common flat key (A) GB1096-79		
齿轮精度等级 Gear precision grade	6 GB/T110095-2008		
电机功率 Motor power	750W		
电机安装尺寸 Motor dimensions	Ø19*35/Ø70*3/4-Ø6.5-Ø90		

标准轴
Standard output shaft

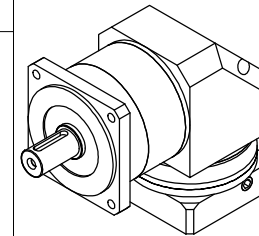
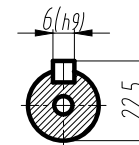

减速比(可选择)	额定转矩(Nm)	最大转矩(Nm)
10	40.0	80.0
7	66.0	132.0
5	95.0	190.0
4	88.0	176.0
3	60.0	120.0

DZF85单级外形图 1-stage						DZF85-L1- -S-P2		
标记	处数	分区	更改文件号	签名	年月日	图号:		
设计			标准化			数量	重量	比例
审核								1:1
工艺			批准			www.dgdjzn.com		

大江智能

